



# Maswell WiFi 4x4 MIMO Antenna Screw Mount WiFi 7 WiFi 6E Bluetooth Zigbee Wimax

AN\_Master\_Cubic\_4W



## Schematic picture

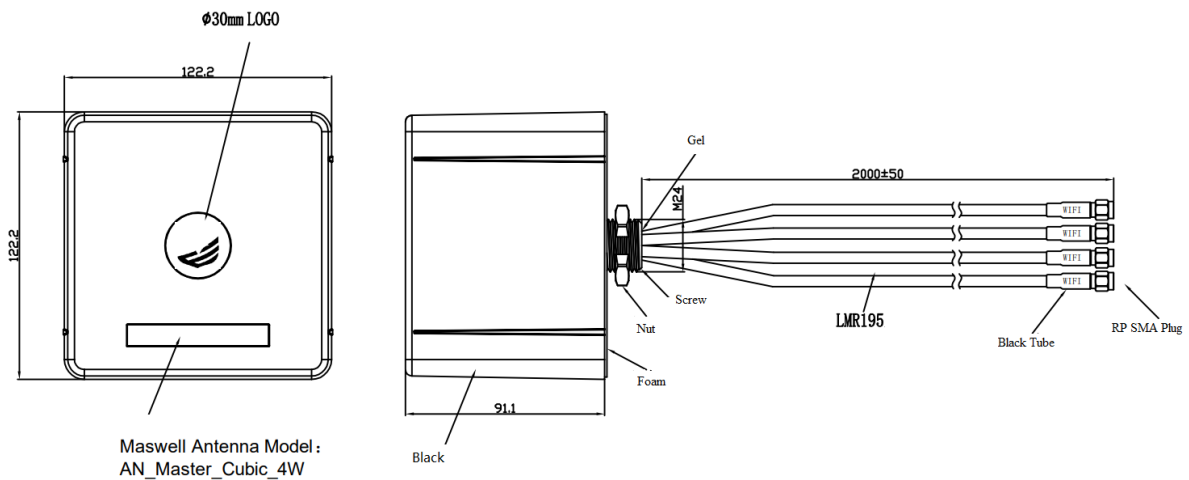

# Maswell WiFi 4x4 MIMO Antenna Screw Mount

## WiFi 7 WiFi 6E Bluetooth Zigbee Wimax

AN\_Master\_Cubic\_4W

### Specifications

Item	Specifications	
Antenna 1: WiFi	Frequency Range	2100Mhz-7200MHz
	Polarization	Linear
	Gain	4dBi
	V.S.W.R	< 1.5
	Impedance	50Ω
Antenna 2: WiFi	Frequency Range	2100Mhz-7200MHz
	Polarization	Linear
	Gain	4dBi
	V.S.W.R	< 1.5
	Impedance	50Ω
Antenna 3: WiFi	Frequency Range	2100Mhz-7200MHz
	Polarization	Linear
	Gain	4dBi
	V.S.W.R	< 1.5
	Impedance	50Ω
Antenna 4: WiFi	Frequency Range	2100Mhz-7200MHz
	Polarization	Linear
	Gain	4dBi
	V.S.W.R	< 1.5
	Impedance	50Ω

# Maswell WiFi 4x4 MIMO Antenna Screw Mount

## WiFi 7 WiFi 6E Bluetooth Zigbee Wimax

AN\_Master\_Cubic\_4W

### Specifications

Item	Specifications	
Mechanical	Dimension	122mm *122mm*91mm
	Connector	RP SMA Plug
	Cable	LMR195 equivalent 2 meters
Environmental	Operating Temperature	-40°C~+85°C
	Waterproof Grade	IP67 EURO: EN 60529:1991+A1:2000+A2:2013 +AC:2019 CHINA: GB/T4208-2017)
	Relative Humidity	Up to 95%
	UV Exposure & Water Immersion	F1 ( UL746C )
	Radome Material	ASA/ (UL Yellow Card)
	Vibration	10 to 55Hz with 1.5mm amplitude 2hours
	Environmentally Friendly	ROHS Compliant

# Maswell WiFi 4x4 MIMO Antenna Screw Mount

## WiFi 7 WiFi 6E Bluetooth Zigbee Wimax

AN\_Master\_Cubic\_4W

### S11 Reflection Coefficient

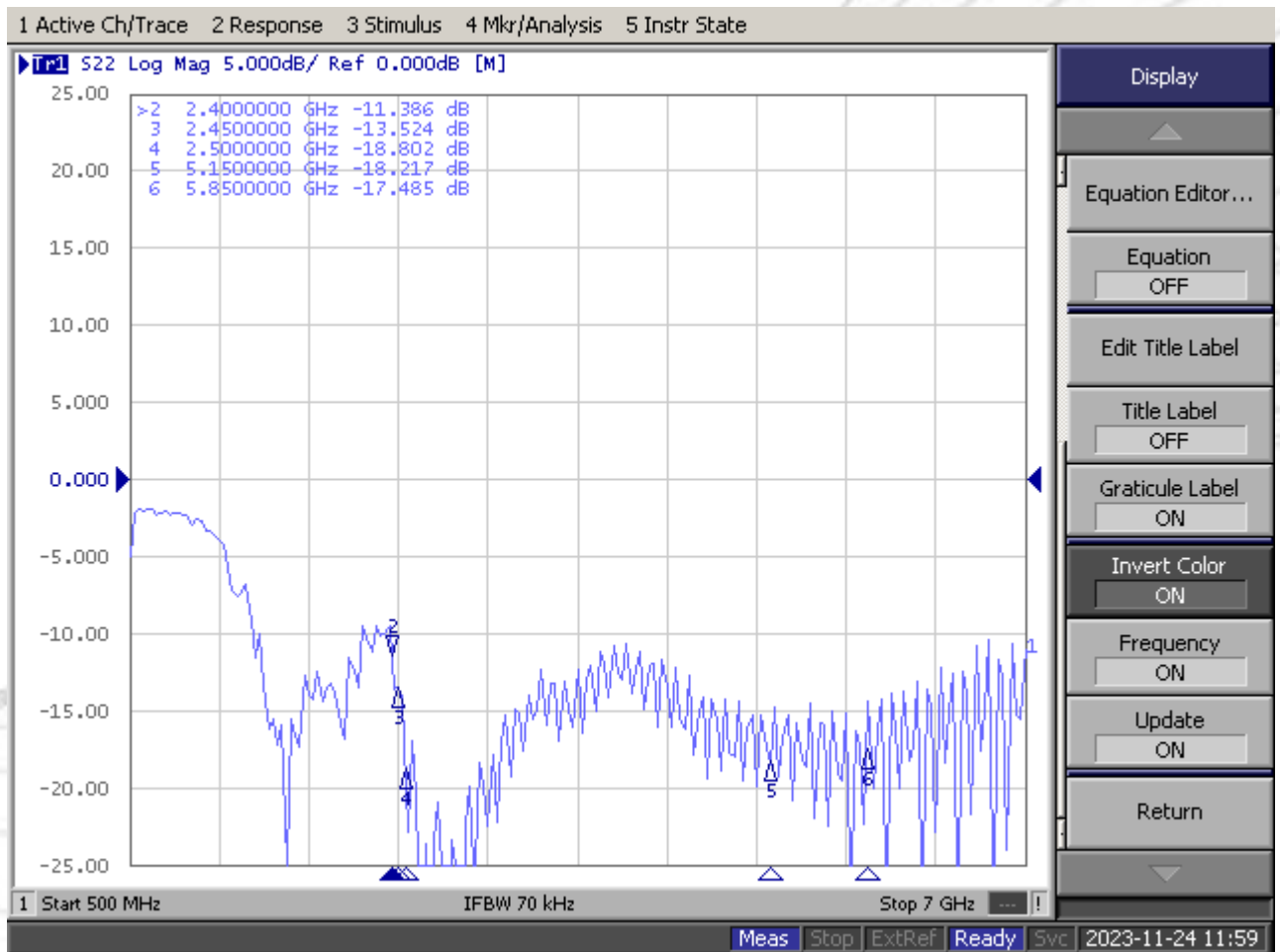



# Maswell WiFi 4x4 MIMO Antenna Screw Mount

## WiFi 7 WiFi 6E Bluetooth Zigbee Wimax

AN\_Master\_Cubic\_4W

### Isolation

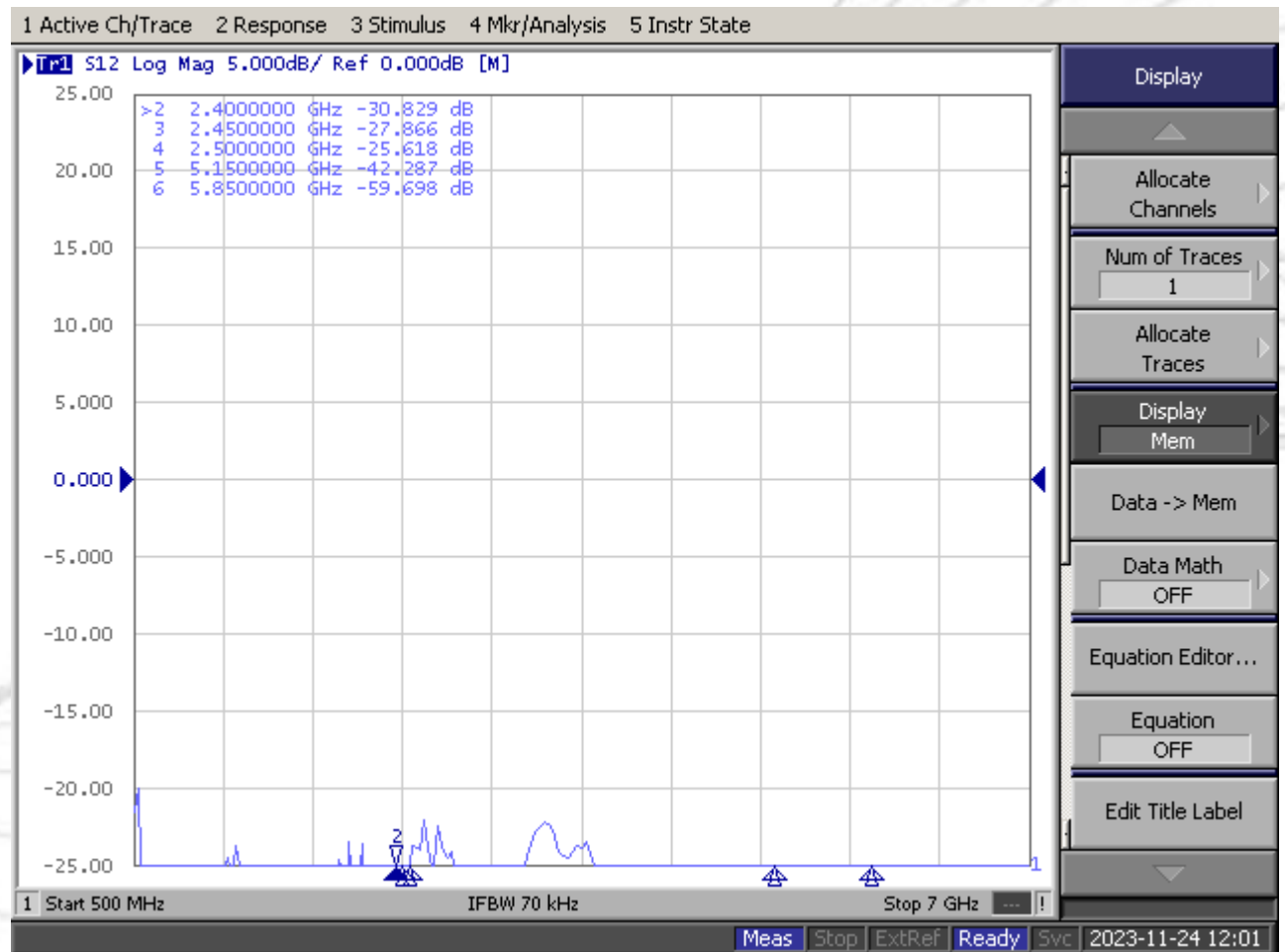

**TEST REPORT**

EN 60529

**Degrees of protection provided by enclosures(IP code)**

Report reference No..... : CTB231113016Q

Date of issue..... : 2023-11-16

**Testing laboratory**

Name Shenzhen CTB Testing Technology Co., Ltd.

Address..... : 1&amp;2/F., Building A, No.26, Xinhe Road, Xinqiao, Xinqiao Street, Bao'an District, Shenzhen, Guangdong, China

Testing location..... : Same as above

**Client**

Applicant..... : Suzhou Maswell Communication Technology Co.Ltd

Address..... : Room 403,Building 1,No.88 Zhenbei Road,High-tech District,Suzhou 215153,Jiangsu,China

**Test specification**

Standard..... : EN 60529:1991+A1:2000+A2:2013+AC:2019

Procedure deviation..... : N/A

Non-standard test method.... : N/A

Object under test..... : Maswell MIMO Cubic Antenna Series

Model/Type reference..... : AN\_Master\_Cubic\_4C/AN\_Master\_Cubic\_2C2W/AN\_Master\_Cubic\_4W and Variants

Others Model..... : /

Trade mark..... : Maswell

Manufacturer..... : Suzhou Maswell Communication Technology Co.Ltd

Address..... : Room 403,Building 1,No.88 Zhenbei Road,High-tech District,Suzhou 215153,Jiangsu,China

IP degrees..... : IP67

**Possible test case verdicts**

- test case does not apply to the test object..... : N/A(Not Applicable)

- test object does meet the requirement..... : P(Pass)

- test object does not meet the requirement..... : F(Fail)

Date of receipt of test item..... : 2023-11-10

Date(s) of performance of tests..... : 2023-11-13 to 2023-11-15

Laboratory sample number..... : 2231110007-1,14

## Model PW-957(+)(f1)

File Number: E56070



### COMPANY

#### CHI MEI CORPORATION

No 398 Sec 1 Zhongzheng Rd  
Rende District  
Tainan City, 717010 Taiwan

### MODEL INFO

PW-957(+)(f1)

Acrylonitrile Styrene Acrylate (ASA) "KIBILAC", furnished as pellets

(f1) – Suitable for outdoor use with respect to exposure to Ultraviolet Light, Water Exposure and Immersion in accordance with UL 746C.

(+) – Indicate 0~0.5% acid scavengers.

FLAMMABILITY PROPERTIES	VALUE	TEST METHOD
<b>Flammability</b>		ANSI/UL 94
1.5 mm, Color: ALL	HB	
3.0 mm, Color: ALL	HB	
ISO/IEC FLAMMABILITY PROPERTIES	VALUE	TEST METHOD
<b>Flammability</b>		IEC 60695-11-10
1.5 mm, Color: ALL	HB75	
3.0 mm, Color: ALL	HB40	
ELECTRICAL PROPERTIES	VALUE	TEST METHOD
<b>Hot-wire Ignition (HWI)</b>		UL 746A
1.5 mm	PLC 4	
3.0 mm	PLC 3	
<b>High Amp Arc Ignition (HAI)</b>		UL 746A
1.5 mm	PLC 0	

3.0 mm	PLC 0	
<b>Comparative Tracking Index (CTI)</b>	PLC 0	UL 746A
<b>High Voltage Arc Tracking Rate (HVTR)</b>	PLC 3	
<b>High Voltage, Low Current Arc Resistance</b>	PLC 6	
<b>THERMAL PROPERTIES</b>	<b>VALUE</b>	<b>TEST METHOD</b>
<b>Relative Thermal Index - Electrical Strength</b>		UL 746B
1.5 mm	90 °C	
3.0 mm	90 °C	
<b>Relative Thermal Index - Mechanical Impact</b>		UL 746B
1.5 mm	90 °C	
3.0 mm	90 °C	
<b>Relative Thermal Index - Mechanical Strength</b>		UL 746B
1.5 mm	95 °C	
3.0 mm	95 °C	
<b>PHYSICAL PROPERTIES</b>	<b>VALUE</b>	<b>TEST METHOD</b>
<b>UV Exposure &amp; Water Immersion</b>	f1	UL 746C

Report Date: 2006-08-31

The appearance of a company's name or product in this database does not in itself assure that products so identified have been manufactured under UL Solutions' Follow - Up Service. Only those products bearing the UL Mark should be considered to be Certified and covered under UL Solutions' Follow - Up Service. Always look for the Mark on the product.

UL Solutions permits the reproduction of the material contained in Product iQ subject to the following conditions: 1. The Guide Information, Assemblies, Constructions, Designs, Systems, and/or Certifications (files) must be presented in their entirety and in a non-misleading manner, without any manipulation of the data (or drawings). 2. The statement "Reprinted from Product iQ with permission from UL Solutions" must appear adjacent to the extracted material. In addition, the reprinted material must include a copyright notice in the following format: "©2024 UL LLC."